



# MATERIA COLLECTION

LUXURY DECOR & BESPOKE SOLUTIONS

NUMERI - Art Collection

---

**LAURAMERONI**  
design . collection



Sideboard with brushed metal legs, inlaid doors and structure. Fitted with push-pull doors and one internal shelf, it is also available in the hanging version.

Numeri sideboard is produced in a Limited Edition of 33 multiples only.

In Numeri, Pop artist Ugo Nespolo fills the two-tone background in shades of blue with a free composition of numbers in brilliant colors, which protrude from the surface of the doors and turn up, coloring, on the top and sides edges. Never totally tied to a trend, Nespolo's art is immediately characterized by an accentuated ironic, transgressive imprint and a personal sense of fun.







Wooden sideboard with decorative inlays and numbers, push-pull doors, equipped with internal shelves.

The numbers protrude from the surface of the doors and colors the sideboard sides. A detail of the particular and exclusive Numeri decoration.

For Nespolo, art is a number and has a rational root that shines throughout all of modernity.

The exclusive design, as a result of our artists' creation, transforms this sideboard into a real work of art, for customers that are looking for unique products. The numbers protrude from the surface of the doors and colors the sideboard top.

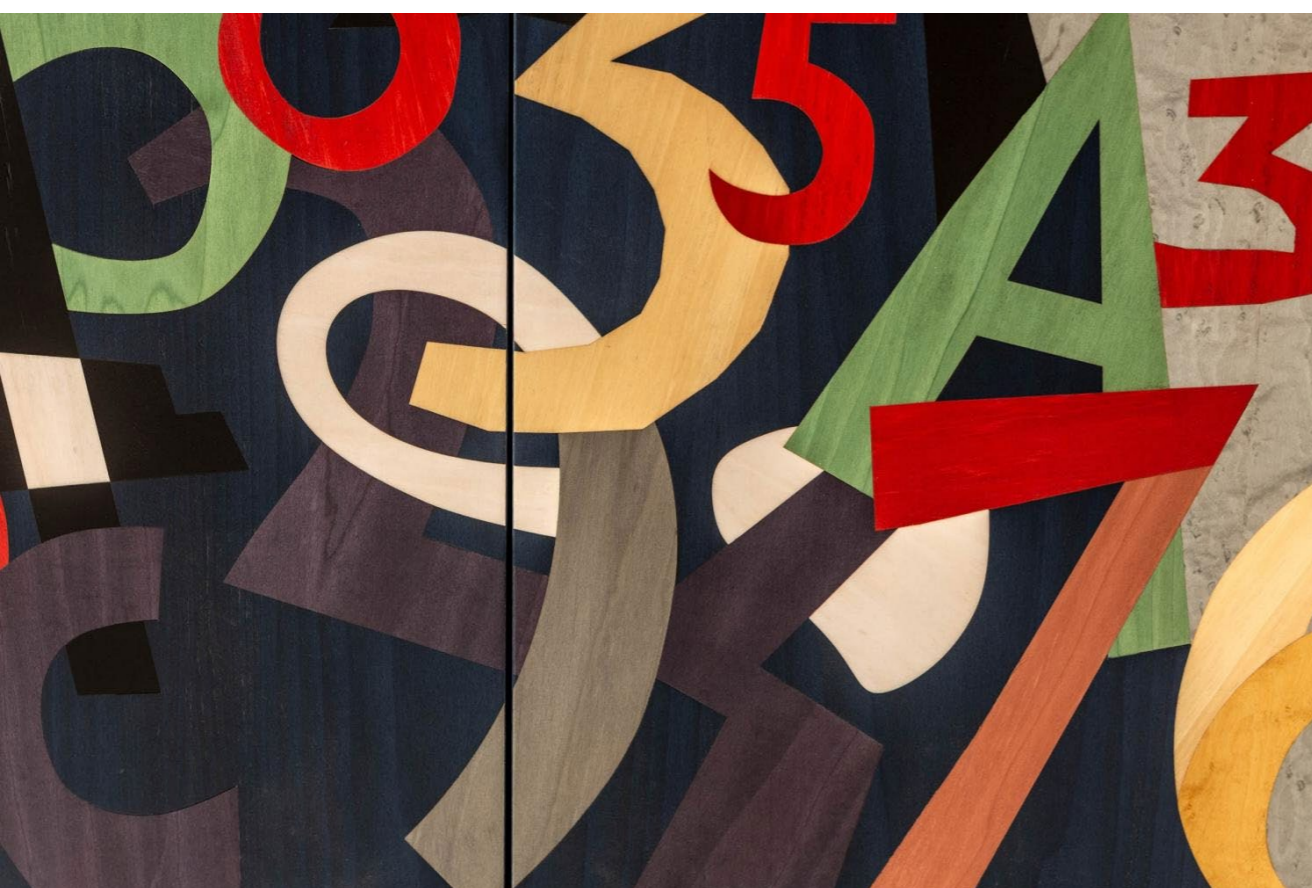





DIMENSIONS

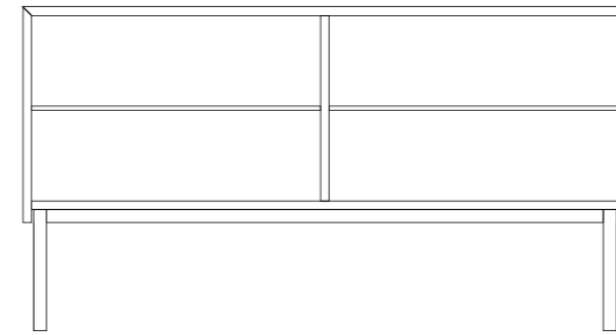

25  
[9 13/16"]

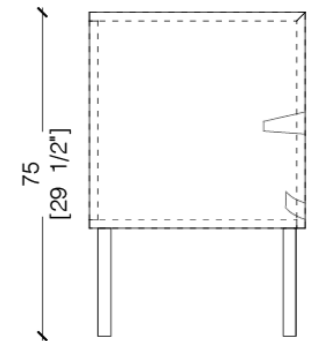

75  
[29 1/2"]

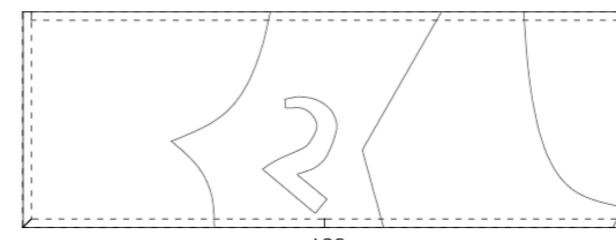

50  
[19 11/16"]

160  
[62 13/16"]

Numeri  
By Ugo Nespolo



**Ugo Nespolo** was born in 1941 in Mosso (BI), he graduated at the Accademia Albertina di Belle Arti in Turin. In the sixties he moved to New York, where he is carried away by the cosmopolitan city life and is fascinated by the emerging Pop Art, while in the seventies he militates in the conceptual and poveristi environments.

Relevant is his passion for cinema that will originate significant retrospectives dedicated to him in important foreign museums (Philadelphia, New York, London, Paris, Cologne, Beijing, Shanghai). He founded with Mario Schifano the Cinema of the artists and between 1967 and 1968 he made various films featuring friends and colleagues such as Enrico Baj, Michelangelo Pistoletto and Lucio Fontana as main characters.

Despite US contaminations, he does not forget the influence of the European avant-gardes. He is also interested in design and his research encompasses the attention to materials: wood, metal, glass, ceramics, cloth, precious stones. His art is, therefore, closely linked to daily life and full of conceptual contributions: "You can not make art without thinking about art."

# MATERIA

---

COLLECTION  
LUXURY DECOR AND BESPOKE SOLUTIONS

1060 Kane Concourse, Bay Harbor Islands, FL 33154

[www.materiacollection.com](http://www.materiacollection.com) | [info@materiacollection.com](mailto:info@materiacollection.com)

1-800-849-4953 | 786-438-1330

LAURAMERONI  
design . collection

U.S.A HEADQUARTERS